

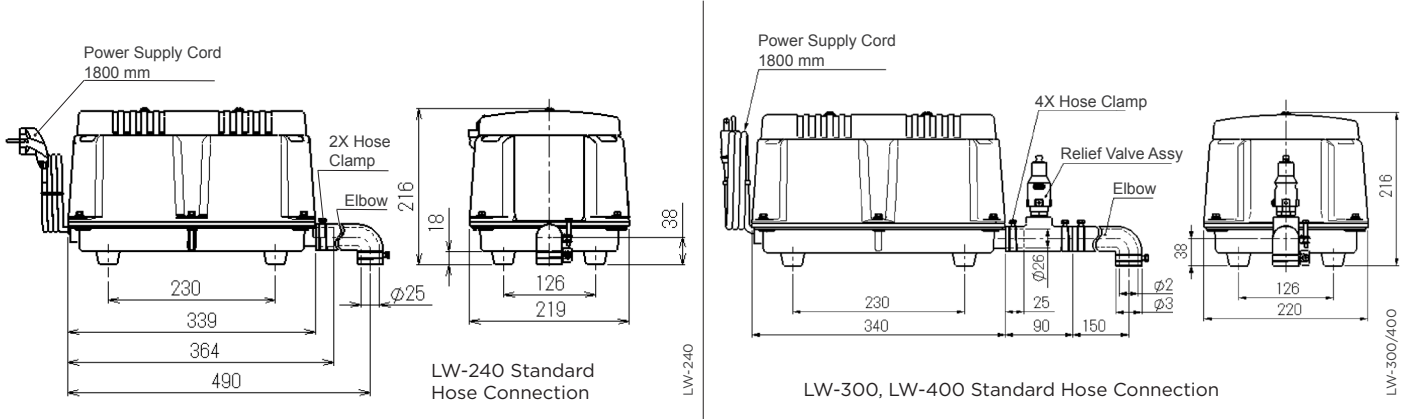

Linear Diaphragm Pumps LW-240, LW-300, LW-400

Flow at rated pressure

425 l/min at 200 mbar



PNEUMATIC DATA

Description	LW-240	LW-300	LW-400
Part number	52500410	52500411	52500414
Flow at rated pressure	240 l/min	350 l/min	425 l/min
Rated pressure	200 mbar	200 mbar	200 mbar
Operating range	100 to 250 mbar	100 to 250 mbar	100 to 250 mbar

ELECTRICAL DATA

Motor type	Linear drive	Linear drive	Linear drive
Nominal Voltage	230V 50Hz	230V 50Hz	230V 50Hz
Consumption at rated pressure	1.8 A/250 W	1.6 A/280 W	2.4 A/400 W

GENERAL DATA

Ambient temperature	-10 to 40 °C	-10 to 40 °C	-10 to 40 °C
Weight	14.4 kg	16.0 kg	16.0 kg
Outlet diameter	26 mm	26 mm	26 mm
Average sound level	49 db (A)	50 db (A)	51 dB (A)

SERVICE PARTS

Chamber block set ¹⁾	700500	700597	700597
Air filter and gasket kit	700502	700598	700598
Air filter kit	700510	700510	700510
Protective switch ¹⁾	700512	700599	700599

All listed values are measured at standard atmospheric conditions.
Please consult factory if 230V 60Hz is needed.
Please refer to the operation manual for additional information.
1) Denotes that part is only available for trained service personnel.

FLOW CURVES

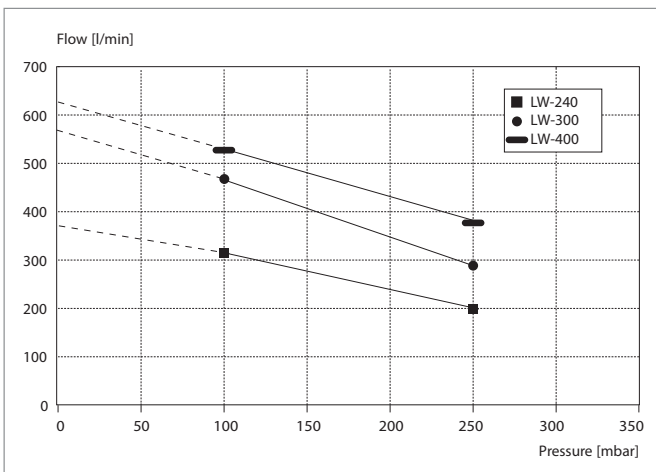

Note: Operation outside specified operating range is not recommended.
All listed values are measured at standard atmospheric conditions

SERVICE PARTS

Chamber block set¹⁾ consists of:
4 x Pump head with valves
4 x Diaphragm assembly
4 x Diaphragm nut
4 x Diaphragm washer

Air filter and gasket kit consists of:
1 x Air cleaner element
1 x Air cleaner gasket
1 x Noise absorbing net
1 x Tank gasket
1 x Cover gasket
4 x L-Hose

Air filter kit consists of:
5 x Air cleaner element
5 x Air cleaner gasket

Protective switch¹⁾ consists of:
1 x Microswitch w/cover plate
Please note: One unit is equipped with two protective switches

SUPPLIED AS STANDARD

Cable/Euro with plug
Air connector consisting of LW-240 (700513)
1 x Outlet hose, angled, 170/50 mm
2 x Hose clamp
LW-300 & LW-400 (P/N 700600)
1 x Outlet hose, angled, 170/50 mm
4 x Hose clamp
1 x Relief valve assembly
1 x Hose connector

Accessory Available:
Air connector, straight type (P/N 700514) consists of
1 x Outlet hose, straight, 150 mm
2 x Hose clamp

5250... Stock programme